

SPS fibre FORM Instrument Custom Cabinet Enclosure Type FFxx.xx.xx

Dimensions: Height x Width x Depth
72" max x 72" max x 36" max
AS REQUIRED BY CUSTOMER

Un-Insulated or Insulated.

SPS/fibreFORM custom cabinet enclosures are "Open Molded" using glass reinforced epoxy vinyl ester resin. The cabinet is light gray in colour with a "Gel-Coat" outer surface for ultimate "UV" protection. Cabinets are complete with stainless steel hinges and a three point closing mechanism. Enclosures use a neoprene gasket to a Nema 4x standard.

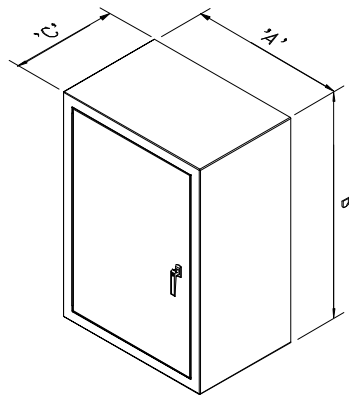
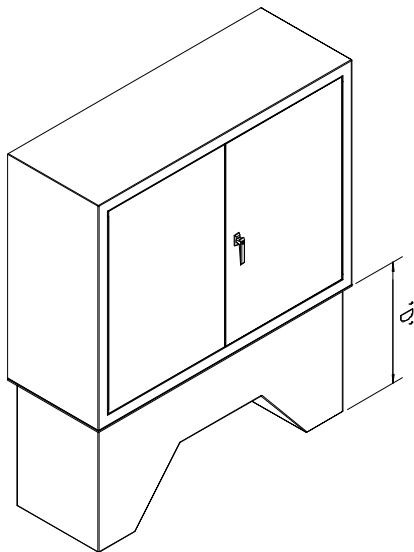

OPTIONS:

- | | |
|------------|--|
| ◇ SI-CUS | - Extra Insulation (Sandwiched Layers) |
| ◇ SD | - Single Door Opening |
| ◇ DD | - Double Door Opening |
| ◇ CMSS | - Stainless Steel Corner Mount Element |
| ◇ BMA | - Bulkhead Mount Area |
| ◇ DL | - External Drip Lip |
| ◇ WB-CUS | - External Surface Mount Bracket |
| ◇ MP-CUS | - Internal Mounting Plate |
| ◇ RMS-CUS | - Internal Mounting Rail System |
| ◇ PW | - Plexiglas Window |
| ◇ SG | - Safety Glass Window |
| ◇ FRPSTAND | - FRP stand to fit cabinet ordered |
| ◇ STLSTAND | - Steel stand to fit cabinet ordered |

Cabinet Information:

'A' - _____
'B' - _____
'C' - _____
'D' - _____

Door Opening:

Height = B - 6 1/2"

Width = A - 7"

Door Window/Panel Area:

(Max) A/B - 12"