

SPS fibre FORM Instrument Protection Enclosure Type FF163

Dimensions: (Approx.) Height x Width x Depth
16"(405mm)x11"(280mm) x 11"(280mm)

Weights: (Approx.)

Un-Insulated 12 lbs. / 5.5 kgs.

Insulated 14 lbs. / 6.5 kgs.

SPS fibre FORM enclosures are "Resin Transfer Molded" with glass reinforced epoxy vinyl ester resin. The outer surface standard is light gray colored "Gel-Coat" for ultimate "UV" protection. Stainless steel hinges and clasps combine with a closed cell neoprene gasket to provide protection.

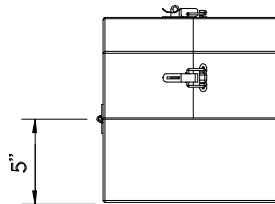
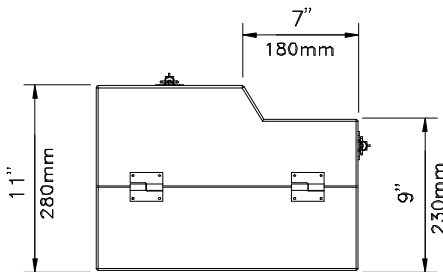
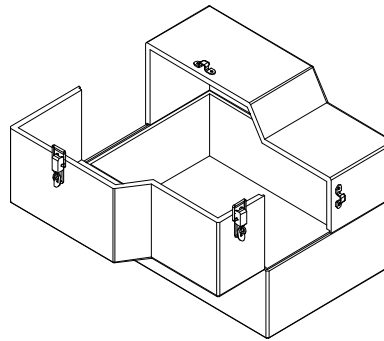
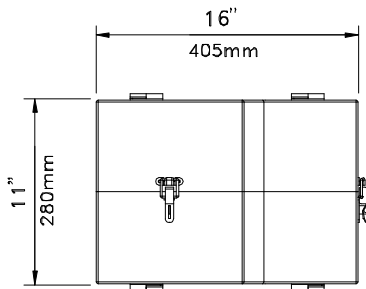

OPTIONS:

- | | |
|--------|-------------------------------------|
| I-PUAL | - Extra Insulation (Aluminum Foil) |
| I-PUFR | - Extra Insulation (FRP coated) |
| I-PUSS | - Extra Insulation (Stainless Foil) |
| LPS | - Stainless Lid Prop-Stay |
| CMSS | - Stainless Steel Corner Mount |
| CMCSP | - Plated Steel Corner Mount |
| IMP | - Internal 2" Instrument Mount Post |
| IMPH | - Internal Horizontal 2" Mount Post |
| IMPV | - Internal Vertical 2" Mount Post |
| EMP | - External 2" Post Mount Hub |
| GMP | - Galvanized Mounting Plate |
| GWB | - Galvanized Wall Mount Bracket |
| RMS | - Internal Mounting Rail System |
| PW | - Plexi-Glass Window |
| SW | - Safety Glass Window |

