

## SPS fibre FORM Non-Metallic Protection Enclosure Type FF166 .....

Dimensions: (Approx.) Height x Width x Depth  
16"(405mm) x 16"(405mm) x 6 3/4"(170mm)  
Wall Thickness: 1/8" / 3 mm  
Weights: (Approx.)  
Un-Insulated 9 lbs. / 4 kgs.

SPS fibre FORM enclosures are "Resin Transfer Molded" with glass reinforced epoxy vinyl ester resin. The outer surface standard is light gray coloured "Gel-Coat" for ultimate "UV" protection. Polypropylene hinges and screws along with flexible draw latches combine with a neoprene gasket to provide protection.

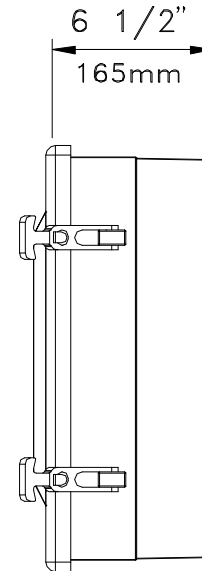
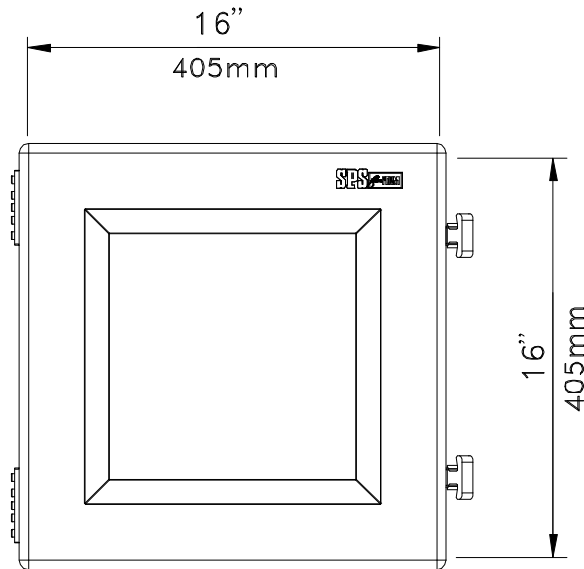

### OPTIONS:

VEGC	- Vinly Ester Gel-Coat
VEFR	- Vinyl Ester Fire Retardant Gel-Coat
PEGC	- Polyester Base Gel-Coat
FSL	- Fiberglass Secondary Latch
PVCCM	- PVC Corner Mount Bolts & Nuts
PVCMF	- PVC Internal Mounting Plate
FMP	- Fiberglass Internal Mounting Plate
FWB	- Fiberglass Wall Mount Brackets
FPB	- Fiberglass 2" Pipe Mount Brackets
FGG	- Fiberglass Secondary Gasket Guard

